

PS-360B

Pneumatic
Compactor



Cat® 3054T Diesel Engine

Gross power	78 kW	105 hp
Maximum operating weight	25 000 kg	55,115 lb
Rolling width	2275 mm	7' 6"

High Production in a Versatile Package



The PS-360B is a pneumatic roller that not only generates high-production results but also is versatile. Its versatility comes from the large and varied ballast capabilities. This allows the PS-360B to be effective on a wide range of applications including soil, asphalt, chip and seal, reclamation, and stabilization.

The amount of compactive force easily can be varied by altering the weight of the ballast. The large ballast chamber can be filled with water, sand, steel or a combination of each. The machine also can be equipped with optional steel ballast configurations. These various ballasting methods allow the machine to be tailored to specific wheel load specifications or contractor preferences.

Another reason for the versatility of the PS-360B is its wide tires and large tire overlap. The tires allow the roller to work on asphalt as a breakdown, intermediate and even a finish roller. And, the broad rolling width easily covers a standard highway lane in two passes.

With its large rubber tires and its high static weight, the PS-360B also is effective on soil. The rubber tires exert a kneading action as well as varying amounts of ground contact pressure that work from the top down to produce density. These characteristics help the pneumatic roller manipulate the material under and between its wheels. The result is a stable, tight finish.

The all-wheel oscillation ensures uniform compaction across the entire rolling width. The oscillating wheels also seek out and compact soft spots that other machines can bridge.

The PS-360B is supported by an extensive dealer network and parts distribution system as well as Caterpillar dealer representatives that are highly trained and motivated. Caterpillar offers a comprehensive line of compactors, asphalt pavers, cold planers, reclaimers and stabilizers.

Caterpillar® 3054T Engine

Reliable and durable diesel engine for years of low maintenance operation.

Precise balance and optimum running speed for smooth operation and long engine life.

High torque rise for maintaining power under increased loads.

Turbocharged engine for optimum performance at high altitude — up to 2134 m (7,000') without derating.

Adjustment-free direct injection performance keeps fuel consumption low.

Meets EPA/CARB low emissions engine regulations.

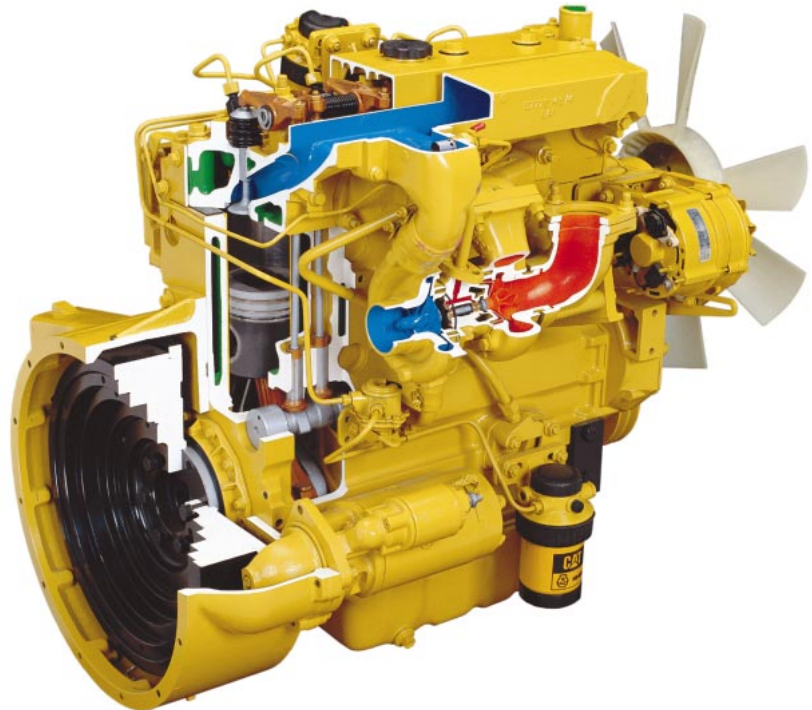

High Drive

Hydrostatic propel system combines smooth stops and starts with plenty of torque.

Power transmission with drive line provides smooth starts and stops — no chains are used.

Hydrostatic transmission provides primary braking — no brake shoes or pads to service.

Easy serviceability to all drive components.

Hydraulic motors, parking brakes and drive lines are positioned high inside the machine frame, eliminating them from contamination and damage.

Two speed ranges provide job site mobility and traction capability to suit working conditions with plenty of propel lever modulation. Speed ranges can be shifted while propelling.

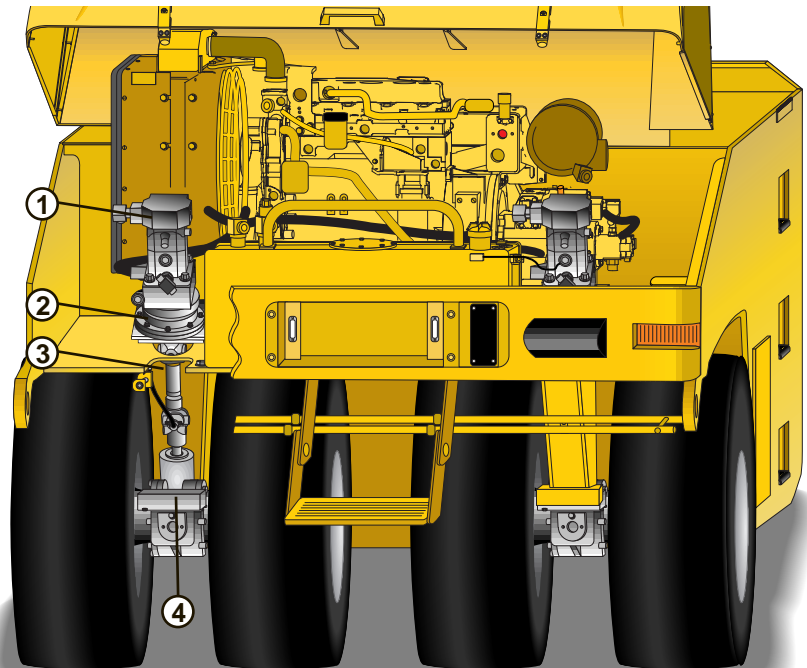

- | | |
|-------------------|------------------------|
| 1 Hydraulic motor | 3 Drive line |
| 2 Parking brake | 4 Axle/Planetary drive |

Operator's Station

Operating ease and comfort promote all-day productivity.

Flat platform increases operator mobility and visibility.

Streamlined gauge control keeps operator informed of engine systems.

Exceptional visibility for easy maneuvering.

Adjustable, cushioned seat provides lasting comfort. Optional suspension seat improves ride.

Single lever control simplifies operation.

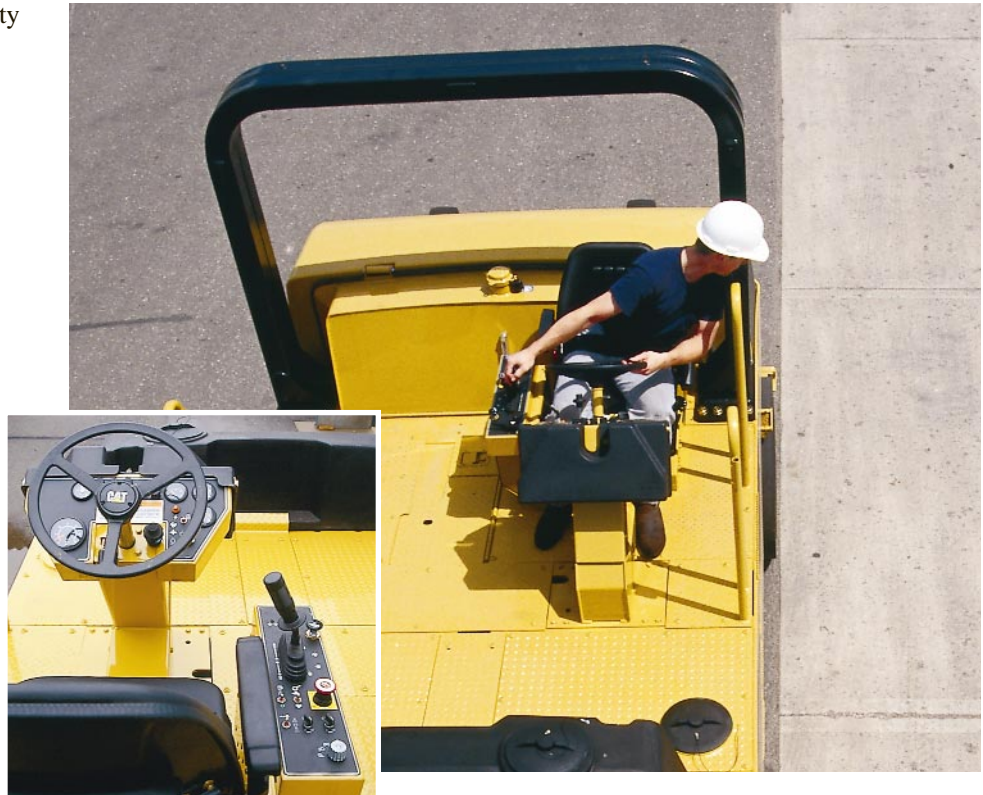

Excellent Forward and Rearward Visibility

Great operator visibility increases production and increases comfort.

Visibility to objects 1 m (3.3') in front of the machine and 1,1 m (3.6') high.

Objects that are 1 m (3.3') behind the machine and 0,7 m (2.3') high can be seen.

Sloped engine enclosure and low-profile front end provide unobstructed sight lines to ground personnel working near machine.



Ballasting

Adding or removing weight from machine is simple and convenient.

Large 5000 L (1,321 gal) water ballast capacity.

Water ballast is conveniently added through a large fill port on the operator's platform and is drained with plug on the bottom of the chamber.

Integral frame baffle plates help prevent surge when water ballasted.

Cover plates are removed easily, providing convenient method to add sand or steel.

Maximum wet sand ballast and steel ballast provides an operating weight of 25 000 kg (55,115 lb).



Tire Overlap/Wheel Oscillation

Wide tires overlap and wheels oscillate for a smooth mat finish.

Front and rear tire paths provide 58 mm (2.25") wide overlap, helping ensure smooth mat finish.

Wide tires and large overlap allow the machine to be used as finish roller on base and intermediate courses.

Broad rolling width of 2275 mm (90") covers a standard highway lane in two passes, with plenty of room to spare.

All-wheel oscillation ensures uniform compaction across entire rolling width and provides excellent bonding of longitudinal asphalt joints.

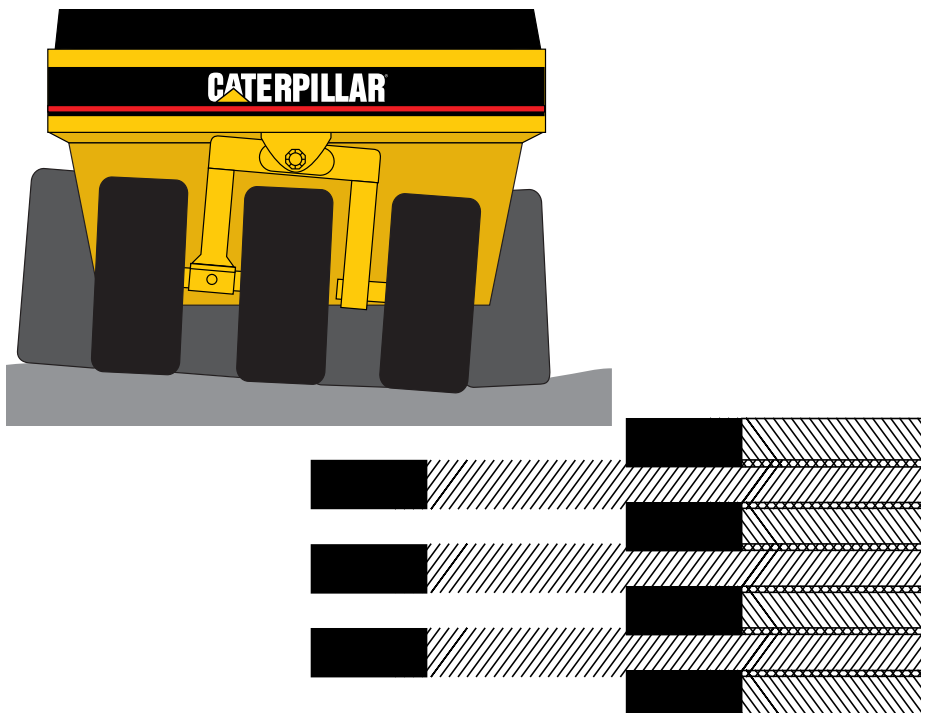

Serviceability

Reduced maintenance requirements mean increased production.

Large engine enclosure pivots upward for access to most routine maintenance points.

Single access to all engine service points and hydraulic filters through engine enclosure.

Rear step provides convenient access.

High drive propel system components are easily accessed at the back of the engine compartment.

Visual indicators simplify verification of fluid levels and filter conditions.

Remote-mounted drains for fuel and cooling systems provides simplified collection of fluids.

Extended-life oils increase maintenance intervals.

Quick-connect hydraulic test ports simplify system diagnosis.



Maximum Visibility Position (MVP) Sliding Operator's Station – Option

Excellent visibility enhances control and increases comfort.

Operator's station slides across the width of the platform and locks into position at the left side, center and right side.

When positioned on either side, the operator has unobstructed visibility to the rear wheel edge contact point.

Seat pivots 30 degrees in all three positions, which can enhance operator comfort when looking rearward.

Gauges and controls move with seat keeping them in the same easy-to-reach locations.

Heavy-duty roller bearings, sliders and frame helps ensure a long and reliable life.



Optional Equipment

Note: Standard and optional equipment may vary. Consult your Caterpillar dealer for specifics.

Maximum Visibility Position (MVP) Sliding Operator's Station slides across the width of the operator's platform and locks into three positions including right, center and left. When in the right or left side positions, the operator has excellent visibility to the rear wheel edge contact point. In addition, the seat pivots 30 degrees right or left, in all three positions. The pivoting seat enhances operator comfort when looking rearward. The sliding station is available with a standard bucket seat or can include the optional suspension seat.

Suspension Seat is mechanical type with vertical adjustment and armrests.

Working Light Package consists of front and rear floodlights.

Roading Light Package consists of front and rear floodlights, red taillights, parking lights with flashers, and turn signals.

Speedometer calibrated in both kilometers per hour and miles per hour on an analog dial.

Combined Ballast Option consists of a set of four internal ballast blocks (4064 kg/8,960 lb), two steel blocks (446 kg/982 lb) bolted into the front bumper and two sets of 51 mm (2") thick bolt-on external steel ballast plates (3084 kg/6,600 lb). The four internal ballast blocks are positioned to maintain equal wheel loads between the front and rear. With wet sand, this option provides an operating weight of 25 000 kg (55,115 lb).

Coco Mats help clean tires, and when used with the either of the spray options, they retain fluids. The coco mats then allow the fluids to seep out of them, providing continuous distribution.

Tire Spray System allows pressurized water to be sprayed over the tires. The entire water spray system is corrosion proof and includes one full-frame polyethylene water tank at the front of the machine. Tank capacity is 394 L (104 gal). A water level gauge is located on the tank within easy sight of the operator. Spray nozzles are positioned above tires and can be removed by hand for cleaning or adjustment. Spray is activated by a switch on the control console.

Tire Wetting System allows a solvent to be sprayed on the tire surfaces, helping prevent asphalt from adhering to the tires. One spray nozzle is positioned above each tire. The system is controlled with a momentary switch on the control console. The system is fed by a 19 L (5 gal) tank located on the right side of the platform.

Heat Retention Shields (Skirts) can help eliminate asphalt from adhering to the tire surfaces by trapping heat that is released from the asphalt. As the roller works on the hot mat, the tires retain the heat and asphalt does not adhere to the tires.

Air-On-The-Run Tire Inflation System allows the operator to inflate or deflate the tires. Tire pressure can be varied from 241 kPa to 758 kPa (35 psi to 110 psi). This option must include 20-ply tires.

20-Ply Tires allow the air pressure to be varied from 241 kPa to 758 kPa (35 psi to 110 psi).

Sun Canopy is a sheet-metal structure that blocks the operator's station from the sun. Structure is bolted to the ROPS.

Value Analysis

Versatile Operation

- Any hot or cold mix, surface seal coating, granular and non-cohesive soils.

Productivity

- High ground contact pressures.
- Responsive diesel power.
- High travel speeds.
- Tires overlap for full-width compaction.
- Wheel oscillation provides uniform compaction.
- Easy ballasting and unloading.
- Nearly equal front-rear weight distribution.

Easy Control

- Single lever control of forward/reverse speeds.
- Low-effort steering.
- Excellent visibility.

Simplified Maintenance

- Simple, durable design.
- Rugged construction for long service life.
- Easy access to all major components.
- Daily maintenance through single location at rear of machine.

Total Customer Support System

Parts availability—most parts on dealer's shelf when you need them. Computer-controlled, emergency search system backup.

Parts stock lists—dealer helps you plan on-site parts stock to minimize your parts investment while maximizing machine availability.

Service capability—dealer's shop or fast field service by trained technicians using latest tools and technology.

Machine management services—effective preventive maintenance programs, cost-effective repair options, customer meetings, operator and mechanic training.

Remanufactured parts—pumps and motors, engines, fuel system and charging system components available from dealer at 20-50% of new part cost.

Literature support—easy-to-use parts books, operation and maintenance manuals, and service manuals help you get maximum value from equipment.

Flexible financing—your dealer can arrange attractive financing on the entire line of Caterpillar equipment. Terms structured to meet cash flow requirements. See how easy it is to own, lease or rent Cat equipment.

Engine

Four-stroke cycle, four cylinder 3054T turbo-charged, diesel engine. Meets EPA and CARB emissions engine regulations.

Ratings at 2,200 rpm	kW	hp
Gross power	78	105

Ratings of Caterpillar machine engines are based on standard air conditions of 25°C (77°F) and 99 kPa (29.32") Hg dry barometer. Power is based on using 35° API gravity fuel having an LHV of 42,780 kJ/kg (18,390 Btu/lb) when used at 30°C (86°F) [ref. a fuel density of 838.9 g/L (7.001 lb/U.S. gal)]. Net power advertised is the power available at the flywheel when the engine is equipped with fan, air cleaner, muffler and alternator.

The following ratings apply at 2200 rpm when tested under the specified standard conditions for the specified standard:

Net Power	kW	hp
ISO 9249	74	100
SAE J1349 (JAN90)	74	99
EEC80/1269	74	100

Dimensions

Bore	100 mm	3.937"
Stroke	127 mm	5"
Displacement	4 L	243 in ³

Dual-element, dry-type air cleaner with visual restriction indicator.

Electrical System

The 24-volt electrical system includes 2 maintenance-free Cat batteries, color-coded and numbered wiring wrapped in nylon braid. The system includes a 45-amp alternator.

Sound Levels

The operator sound pressure level measured according to the procedures specified in SAE J919 APR95 is 82.5 dB(A).

Brakes

Service brake features

Closed-loop hydrostatic drive system provides dynamic braking during machine operation.

Secondary and parking brake features Spring-applied/hydraulically released disc brakes are actuated by a switch on the control console. They are also activated automatically if pressure is lost in the brake circuit or when the engine is shut off. Brake systems meet SAE standard J1472 MAR92.

Transmission

Two speed hydrostatic propel system. Hydrostatic pump provides oil to two hydrostatic motors mounted above the drive axles. Drive shafts connect the motors to the axles.

A single propel lever located on the control console provides smooth hydrostatic control of the infinitely variable speeds in both forward and reverse.

PS-360B Speeds (forward and reverse):

Low	0-8 kmph (0-5 mph)
High	0-18 kmph (0-11 mph)

Axles

Each set of rear wheel pairs are mounted directly to heavy-duty planetary drives.

Service Refill Capacities

	Liters	U.S. Gallons
Fuel Tank	200	52.8
Cooling system	28	7.3
Engine oil (w/filter)	7,3	1.9
Brake	0,6	0.13
Axle	7,5	2
Hydraulic tank	90	23.7
Tire spray tank (optional)	394	104
Emulsion tank (optional)	19	5

Steering

Steering is hydraulic power-assist for responsive, low-effort machine handling.

Minimum turning radius:

Inside 3470 mm

Outside 6700 mm

Steering Angle (each direction) 38.4°

Hydraulic system

One 76 mm (3") bore, double-acting cylinder powered by a gear pump.

Output @ 1200 rpm with 689 kPa 6,8 bar (100 psi) 11,6 Lpm (3 gpm)

Wheels and Tires

14/70 x 20 12-ply tires

3 wheels front, 4 wheels rear

Each tire is equipped with a replaceable scraper. The scrapers help clean asphalt or soil off the tires. The scrapers can be positioned above the tires when they are not needed.

Rear tires extend 58 mm (2.25") outside the width of the frame. Front and rear wheels oscillate to provide uniform compaction across entire rolling width. This also ensures excellent bonding of longitudinal asphalt joints.

Frame

Fabricated from welded heavy gauge steel plates. Integral baffle plates prevent water surge when water ballasted.

Ballast compartments have cover plates. Frame is designed to provide approximately equal loading per wheel with all types of ballast.

The clean, unitized design provides a flat deck for excellent operator mobility. The frame is designed for easy access to all major components.

Protective Structure

Roll Over Protective Structure (ROPS) is a two-post structure that bolts directly onto flanges welded to the machine frame. Meets SAE recommended practice J1040 MAY94.

Instrumentation & Gauges

The start switch, alternator indicator light, coolant temperature gauge, engine oil pressure gauge, hydraulic oil temperature gauge and hour meter are located on the instrument panel in front of the operator. Machine instrumentation and most controls are located at the operator's right on the control console. This includes the propel lever, speed selector switch, spray system controls, horn and secondary/parking brake switch.

Ballast Considerations and Ground Contact Pressures

The most common method of changing ground contact pressure is to vary the tire pressure. Another means to change ground contact pressure is to alter the ballast. The PS-360B can be ballasted with sand, water, steel or a combination of each. These three components provide varying weight capacities, allowing the machine to be tailored to specific requirements.

Ballast Compartments

Ballast compartments are positioned with a calculated balance of wheel to weight ratio. Internal-frame baffles help prevent surges when water ballasted.

Sand and steel ballast can be added through large cover plates on the operation deck, and water can be added through a fill port.

Sand and steel ballast can be removed through a bolt-on side cover, and water ballast can be emptied through a drain port.

Ballast capacity:
5 cubic meters (177 cubic feet)
5000 L (1,321 gal)

Weight of ballast material

.028 cubic meters (1 cubic foot) of wet sand weighs 57 kg (125 lb).

.028 cubic meters (1 cubic foot) of water weighs 28 kg (62.4 lb).

Dimensions

A	Length	4930 mm	16' 2"
B	Compaction width	2275 mm	7' 6"
C	Frame width	2150 mm	7' 1"
D	Height at steering wheel	2530 mm	8' 4"
E	Height with ROPS	3200 mm	10' 6"
F	Wheel base	3650 mm	12'
G	Ground clearance	252 mm	10"
	Outside turning radius	6700 mm	22'
	Inside turning radius	3470 mm	11' 5"
	Tire Overlap	58 mm	2.25"

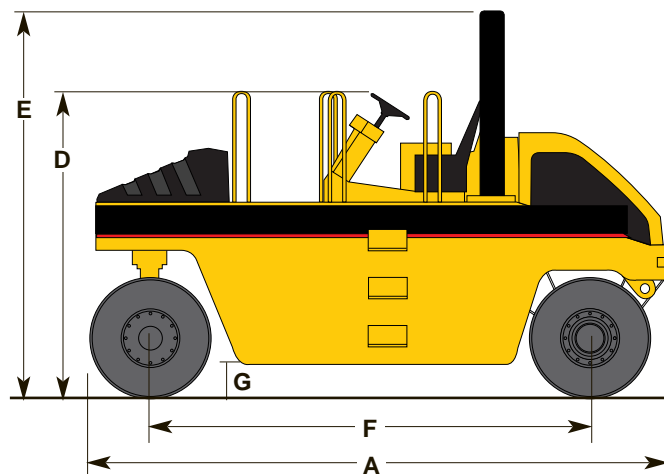
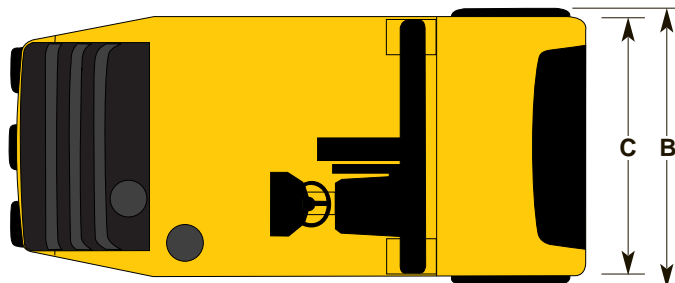

Weights (approximate)

Operating weights include lubricants, coolant, 80 kg (175 lb) operator, full fuel tank, and full hydraulic system.

Operating Weights

Condition	Weight of Ballast	Total Weight	Average Wheel Load
Standard machine empty	none	8500 kg 18,740 lb	1215 kg 2,675 lb
Maximum water ballast only	5010 kg 11,045 lb	13 500 kg 29,760 lb	1930 kg 4,250 lb
Steel ballast only	7595 kg 16,744 lb	15 995 kg 35,265 lb	2285 kg 5,040 lb
Maximum wet sand ballast only	10 036 kg 22,125 lb	18 500 kg 40,785 lb	2645 kg 5,830 lb
Maximum water ballast and steel ballast	12 076 kg 26,622 lb	20 000 kg 44,090 lb	2855 kg 6,300 lb
Maximum wet sand ballast and steel ballast	16 626 kg 36,653 lb	25 000 kg 55,115 lb	3570 kg 7,870 lb
Shipping weight	8320 kg 18,345 lb		
ROPS	260 kg 570 lb		
Steel ballast	7595 kg 16,744 lb		

Productivity and Performance Recommendations

Features

- 2275 mm (7' 6") compaction width
- 368 mm (14.5") wide tires with 58 mm (2.25") wide tire overlap
- Actual GCP up to 965 kPa (140 psi)
- Wide, square-shouldered tires provide even GCP
- Air-on-the-run tire inflation system option

Applications

- Provides full coverage with two side-by-side passes on mat widths up to 4,4 m (14' 6").
- High compaction on asphalt and soil jobs.
- Extra wide tires and large tire overlap help minimize rutting on asphalt jobs.
- High compaction on soil lifts or on harsh asphalt mats.
- Enhances compaction quality when smoothness is an issue.
- Enhances versatility of machine by allowing the tire air pressure to be easily changed depending on job conditions.

Average Ground Contact Pressures

14/70x20, 12-Ply Tires

		12-Ply Tires								
Tire Pressure	kPa	207	241	276	310	345	379	414	448	
	psi	30	35	40	45	50	55	60	65	
Average Wheel Load		Ground Contact Pressures and Contact Areas								
1215 kg (2,675 lb)	GCP	kPa	287	300	326	342	352	359	372	395
		psi	42	44	47	50	51	52	54	57
	CA	cm ²	415	397	365	349	339	332	320	301
in ²		64	62	57	54	52	51	50	47	
1930 kg (4,250 lb)	GCP	kPa	319	333	355	371	381	391	408	427
		psi	46	48	51	54	55	57	59	62
	CA	cm ²	594	569	534	510	497	484	464	444
in ²		92	88	83	79	77	75	72	69	
2155 kg (4,752 lb)	GCP	kPa	329	343	364	380	390	401	419	437
		psi	48	50	53	55	57	58	61	63
	CA	cm ²	643	616	581	556	541	527	504	484
in ²		100	95	90	86	84	82	78	75	
2500 kg (5,513 lb)	GCP	kPa	344	359	377	394	405	416	437	452
		psi	50	52	55	57	59	60	63	66
	CA	cm ²	713	683	650	622	606	589	562	543
in ²		111	106	101	96	94	81	87	84	
2645 kg (5,830 lb)	GCP	kPa	350	366	383	400	411	422	444	458
		psi	51	53	56	58	60	61	64	66
	CA	cm ²	741	710	678	648	632	614	584	566
in ²		115	110	105	100	98	95	91	88	
2855 kg (6,300 lb)	GCP	kPa	359	375	391	409	419	432	454	468
		psi	52	54	57	59	61	63	66	68
	CA	cm ²	779	746	716	685	668	649	616	599
in ²		121	116	111	106	104	101	96	93	
3570 kg (7,870 lb)	GCP	kPa	391	408	419	438	449	463	490	499
		psi	57	59	61	64	65	67	71	72
	CA	cm ²	896	859	835	799	781	756	714	702
in ²		139	133	129	124	121	117	111	109	

Average Ground Contact Pressures

14/70x20, 20-Ply Tires

		20-Ply Tires									
Tire Pressure	kPa	241	310	379	448	517	586	655	724	758	
	psi	35	45	55	65	75	85	95	105	110	
Average Wheel Load		Ground Contact Pressures and Contact Areas									
1540 kg (3,390 lb)	GCP	kPa	296	338	345	372	400	448	469	469	489
		psi	43	49	50	54	58	65	68	68	71
	CA	cm ²	509	446	437	405	377	336	322	322	308
in ²		79	69	68	63	58	52	50	50	48	
1930 kg (4,250 lb)	GCP	kPa	317	345	365	386	413	455	469	489	496
		psi	46	50	53	56	60	66	68	71	72
	CA	cm ²	596	548	517	490	457	415	403	386	381
in ²		92	85	80	76	71	64	63	60	59	
2505 kg (5,510 lb)	GCP	kPa	338	372	393	413	441	469	510	517	524
		psi	49	54	57	60	64	68	74	75	76
	CA	cm ²	725	658	624	592	555	523	480	474	468
in ²		112	102	97	92	86	81	74	73	73	
2865 kg (6,300 lb)	GCP	kPa	351	379	413	434	455	496	524	531	565
		psi	51	55	60	63	66	72	76	77	82
	CA	cm ²	797	739	677	645	616	564	535	528	496
in ²		124	115	105	100	95	88	83	82	77	
3575 kg (7,870 lb)	GCP	kPa	372	407	427	462	482	524	558	558	572
		psi	54	59	62	67	70	76	81	81	83
	CA	cm ²	940	860	819	758	725	668	627	627	612
in ²		146	133	127	117	112	104	97	97	95	

GCP—Ground Contact Pressure CA—Ground Contact Area

Actual Ground Contact Pressures for 14/70x20, 12-Ply Tires

Actual Ground Contact Pressures are measured across the width of the tire. The charts include wheel path overlap.

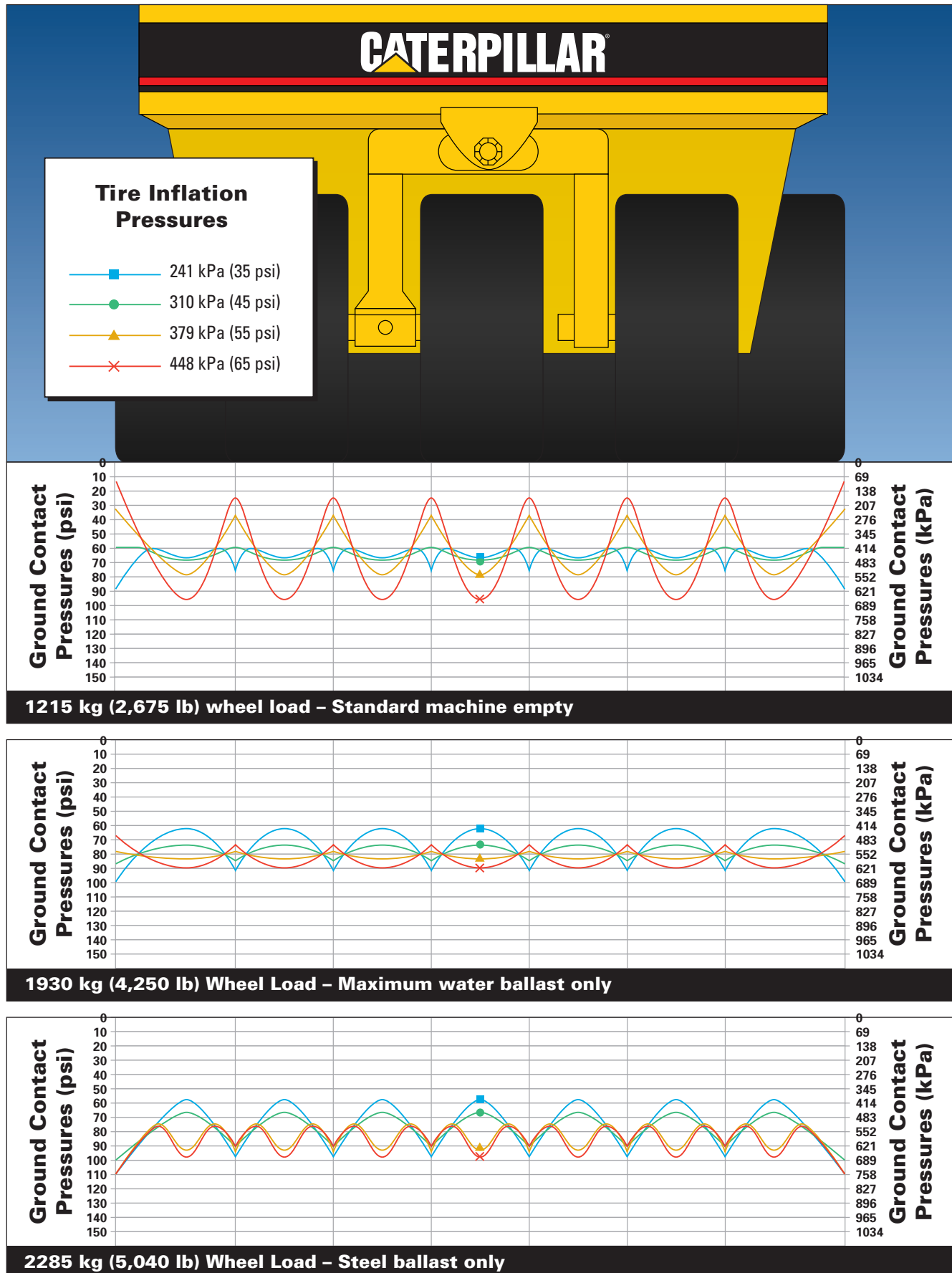

Actual Ground Contact Pressures for 14/70x20, 12-Ply Tires

Actual Ground Contact Pressures are measured across the width of the tire. The charts include wheel path overlap.

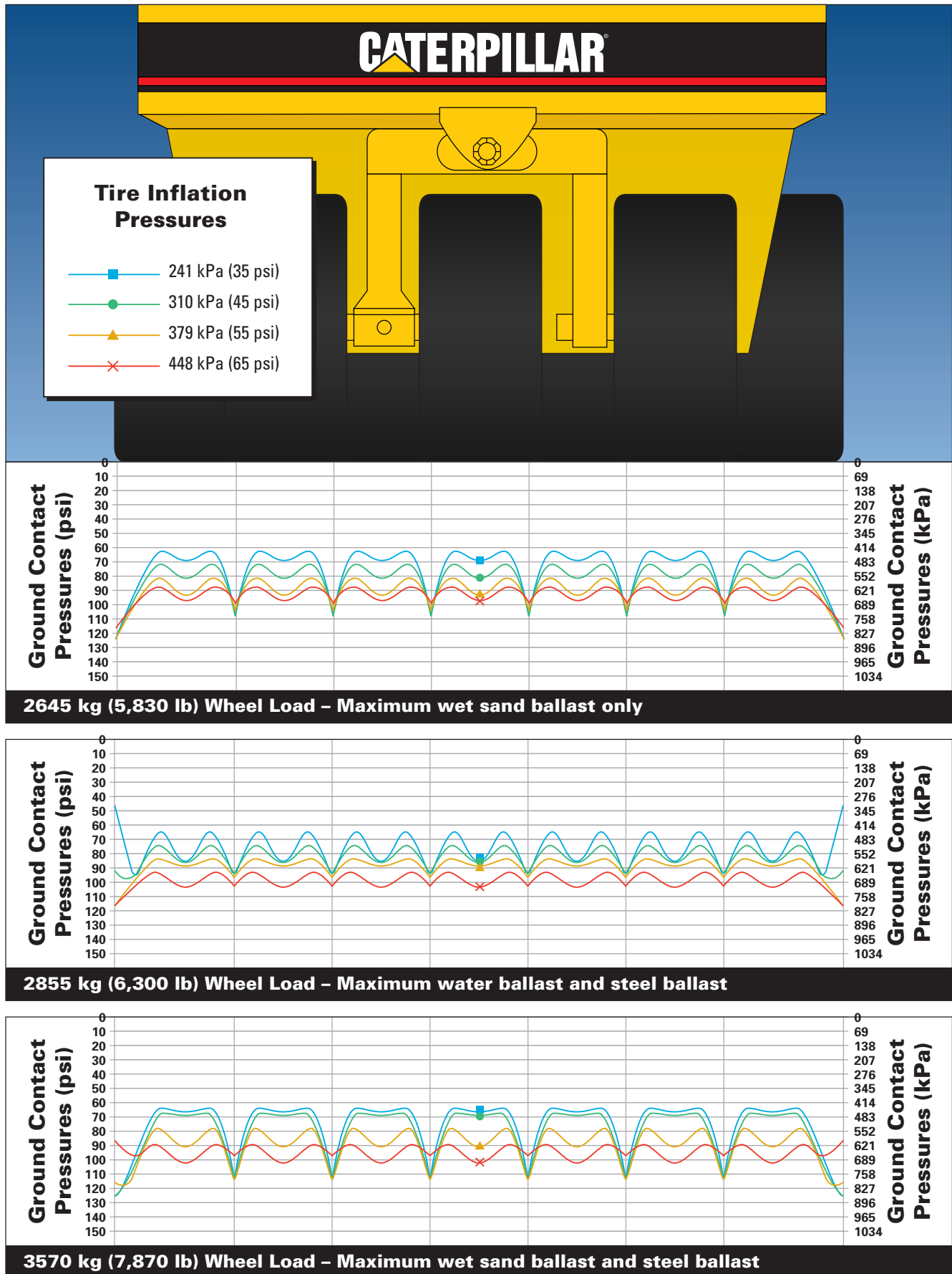

Actual Ground Contact Pressures for 14/70x20, 20-Ply Tires

Actual Ground Contact Pressures are measured across the width of the tire. The charts include wheel path overlap.

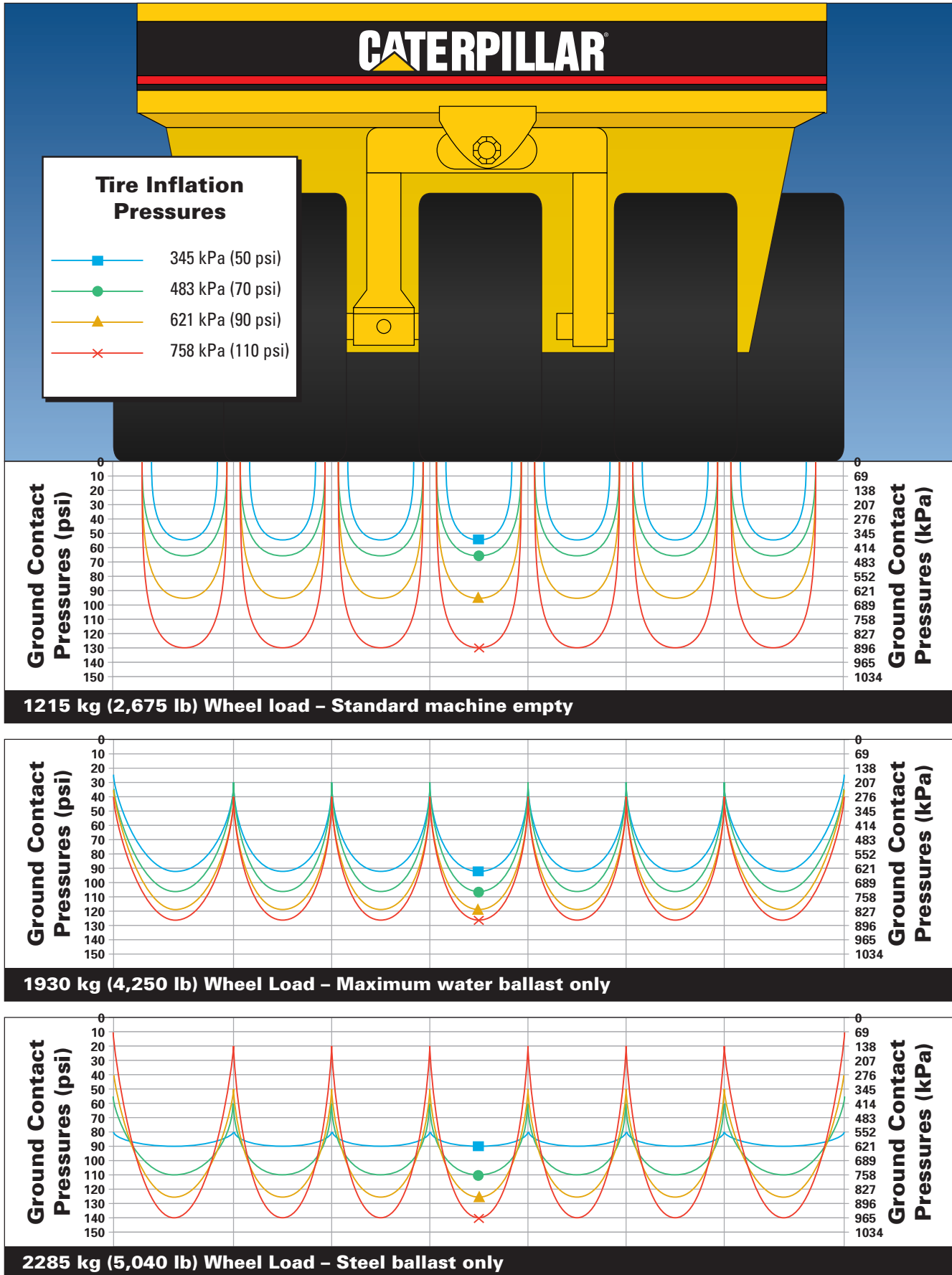

Actual Ground Contact Pressures for 14/70x20, 20-Ply Tires

Actual Ground Contact Pressures are measured across the width of the tire. The charts include wheel path overlap.

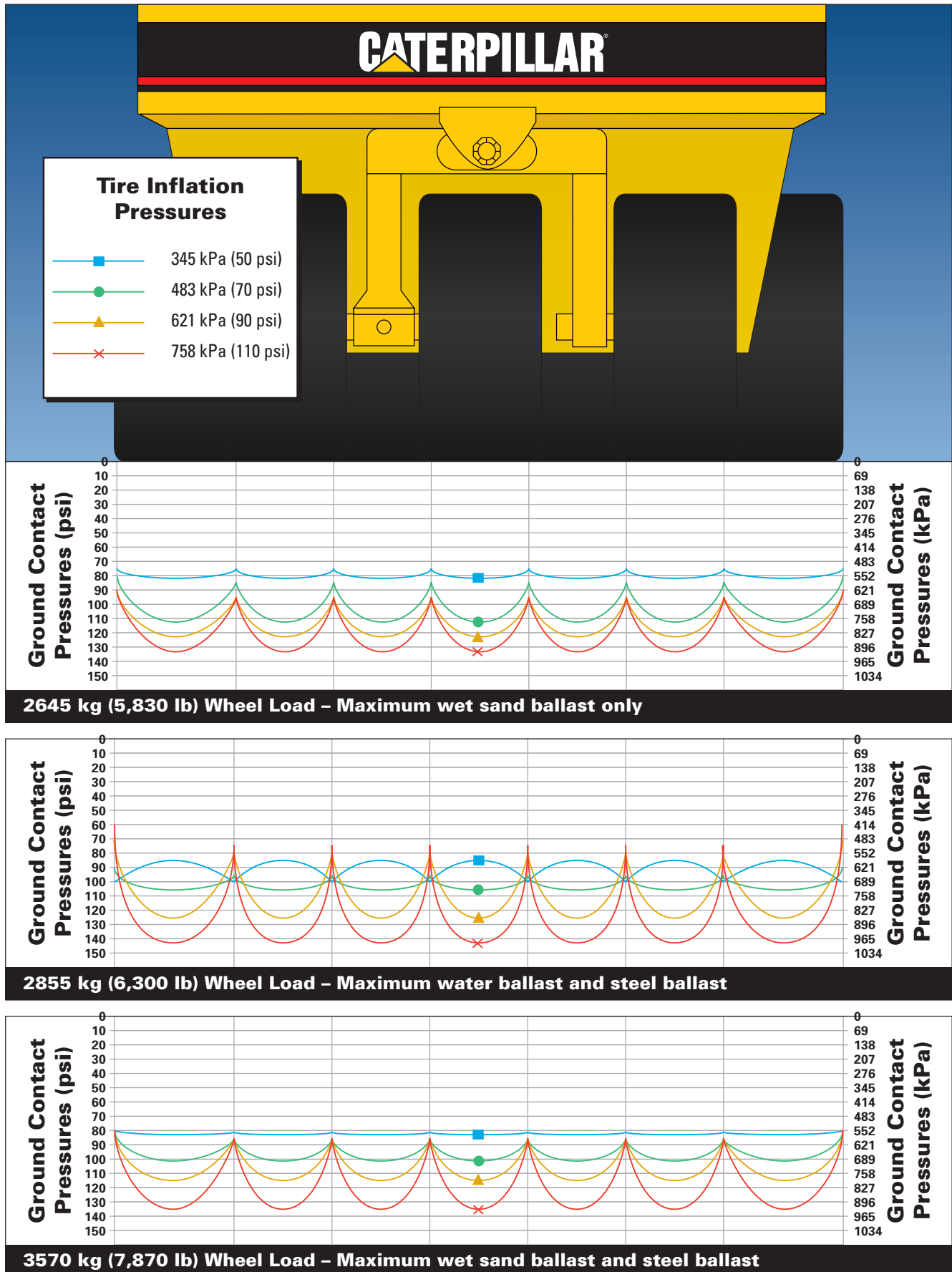

© 2000 Caterpillar

QEHQ9445-02 (6/00)
Replaces QEHQ9445-01

Materials and specifications are subject to change without notice.

